

Skirting board convectors

Skirting board convectors are long, low units, installed in place of conventional skirting boards. Heat is given off primarily by natural convection, as cooler air enters near the base of the unit, is warmed, and rises out through a top opening. Skirting board convectors may be useful where wall space is limited, or if panels are considered incompatible with the decor. Units with individual control valves should be installed to maximise comfort and efficiency. They are unsuitable for use in rooms with high ceilings, or in draughty areas. To ensure even heat distribution, skirting convectors should only be installed on external walls—never on internal walls.

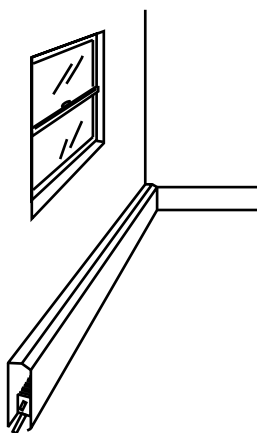

Skirting board convector

Fan convectors

Fan convectors are installed on a wall. These units incorporate a fan to blow hot air into the room. As they are smaller than panel radiators, they are especially suitable where wall space is limited, but should only be used in well-insulated rooms with low to moderate ceiling heights. Fan convectors should be fitted with a temperature-limiting valve to enable heat output to be controlled.

Features to look for

- > If using a gas-fired system, choose a low water content boiler. Storage boilers have slightly higher running costs due to continual 'standing' heat loss from their tanks.
- > Low water content boilers should be manufactured from a lightweight metal such as steel or copper. Avoid cast iron or similar heavyweight materials.
- > Choose panels with a low water content. This improves response time and reduces energy use.
- > Response time—pressed steel panels have a faster response time than cast iron panels, and are around 10–15 minutes quicker in heating a room.
- > All piping should be well insulated to guard against heat loss. Materials such as Armaflex, Bradflex or Insulzip of at least 10 mm thickness should be used—ordinary pre-lagged copper pipe is insufficient.
- > A thermostat should be installed in the main living area (usually the family room). This should be located on an internal wall in an area free of draughts, and away from sources of direct heat, such as system panels or direct sunlight. Programmable thermostats give a higher degree of control than conventional types.
- > Panels in other rooms should have individual valves, allowing rooms to be heated independently. Individual room heating can substantially lower running costs.
- > Thermostatic valves are generally recommended, especially in rooms that gain heat from other sources such as direct sunlight. Increased comfort levels are achieved as desired temperatures are maintained.
- > Consider mounting an insulating board on any uninsulated walls behind panels to reduce heat loss. Up to 30% of heat produced can be lost through such walls. Thin foil board or foil alone is practical and economical.

- > Good overall system design is critical and should be done by a professional with experience in designing hydronic systems.
- > Only heat the rooms you are in or will immediately use and not your whole house unless necessary.
- > At night, turn the system off or set the thermostat to less than 12°C.
- > Maintain the thermostat on the lowest comfortable temperature (18–20°C in living areas). Bedrooms, studies, halls and other infrequently-used areas should be heated to a maximum of 16–18°C.

What type of panels?

Although known as panel ‘radiators’, panels provide both radiant and convective heat output. Radiant heat is emitted from hot surfaces and heats objects in a room directly, but does not directly warm the room air. Convective heat comes from air being warmed and circulated around a room. In general, consider maximising the amount of radiant heat output if you have higher ceilings (3.0 metres or above). A higher proportion of radiant heat also tends to maximise the comfort of room occupants.

The following diagram shows the different types of hydronic panels which are available:

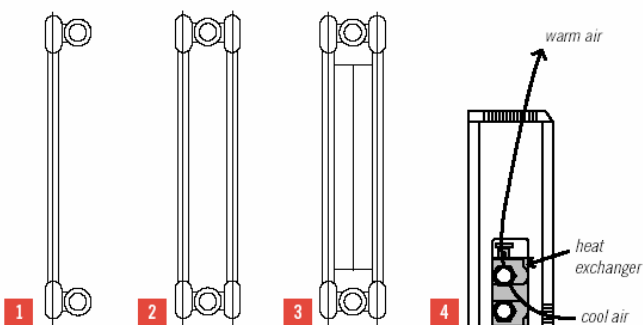

Types of hydronic panels

The approximate proportions of radiant and convective heat from the different types of panels are as follows:

Diagram No.	Type of panel	Radiant output (%)	Convective output (%)
1	Single panel radiator	70	30
2	Double panel radiator	50	50
3	Triple panel radiator	30	70
4	Convector panel	–	100

What fuel should I use?

If you live in an urban area, the cheapest fuel is natural gas. Solid fuel is an option, but is only more economical if it is available at little or no cost (\$60 per tonne or less). If natural gas is not available, the cheapest fuel is generally solid fuel. However, intensive labour is required to keep the boiler operating effectively. LPG is an option in areas without natural gas, but is more than two and a half times more expensive, depending on where you live.

Can I use my hydronic heating system to supply domestic hot water?

Many hydronic heating boilers are also able to provide domestic hot water. These are often referred to as 'combination' boilers. Generally, providing hot water will add approximately \$400–\$500 to the cost of a low water content boiler and up to \$900 to the cost of a storage boiler. Hydronic systems provide 'instantaneous' domestic hot water, similar to that produced by continuous flow hot water systems, but are generally less efficient for this purpose than most domestic hot water systems.

What about solar?

Solar hot water systems can be used to provide hot water for your hydronic system. These 'combination' systems are now commercially available. Solar power is also the most environmentally-friendly fuel source as it does not contribute to greenhouse pollution.

The information in this document is derived from various sources and is understood to be correct at the time of publication. However, the information may not be error free and may not be appropriate for a particular purpose. The Sustainable Energy Authority accepts no liability whatsoever to any person for any injury, loss or damage that may arise in connection with any use or reliance on the information.

June 2004